

INSTALLATION OPERATION AND MAINTENANCE INSTRUCTIONS RUBBER FLEXIBLE JOINT - THREADED

Working temperature 0 °C/100 °C

PRE – INSTALLATION:

The expansion joint should be installed close to a main anchor, and should be followed by a pipe guide which prevents displacement of the line. Be sure all pipe lines are supported so expansion joints do not carry the pipe load. Make sure the mating ends of the pipeline are in line and correct distance apart.

INSTALLATION:

Piping system must be adequately anchored to limit the pipe movements the joint must absorb. If anchoring is not possible, control units must be used so that movements (axial, lateral, and angular) do not exceed maximum published allowable movements. Movement beyond recommended guidelines will result in premature failure. If the expansion joint must be installed with an initial misalignment, compression, or extension, then the maximum allowable movements are reduced by the amount of the initial deflection. Do not cover expansion joints with insulation as this makes it difficult to detect leaks and could restrict movement of the joint. Welding should not be performed in the vicinity of a rubber joint. If it is imperative to weld nearby, cover the joint with a welding cloth and pack the pipe in dry ice to prevent heat transfer. Do not mate to butterfly valves or inlet side of check valve.

A suitable thread sealant (ex. PTFE tape) should be applied to male tapered threads to assure a "leak-tight" seal.

STORAGE, PROTECTION, OPERATION, DISASSEMBLY AND MAINTENANCE

STORAGE AND PROTECTION:

CAUTION: IF THE RUBBER JOINT IS TO BE STORED FOR A LONG PERIOD OF TIME BEFORE INSTALLATION IT SHOULD BE STORED IN A COOL, DRY AND CLEAN WAREHOUSE TO PREVENT DAMAGING EFFECTS.

OPERATION:

The joint absorbs the pipe movements, vibration, noise and shock.

MAINTENANCE:

- Before disassembly or maintenance, assure that the pressure is not present in the pipeline. Periodically check the outside cover of the joint for damage. Replace any joint with cracks or gouges. During maintenance shutdowns, remove joints and inspect the interior for deterioration. Replace any joint which shows signs of wear. For critical lines, it is recommended that a spare expansion joint be kept on hand to be used in the event of failure. This will minimize equipment downtime while a replacement joint is ordered.

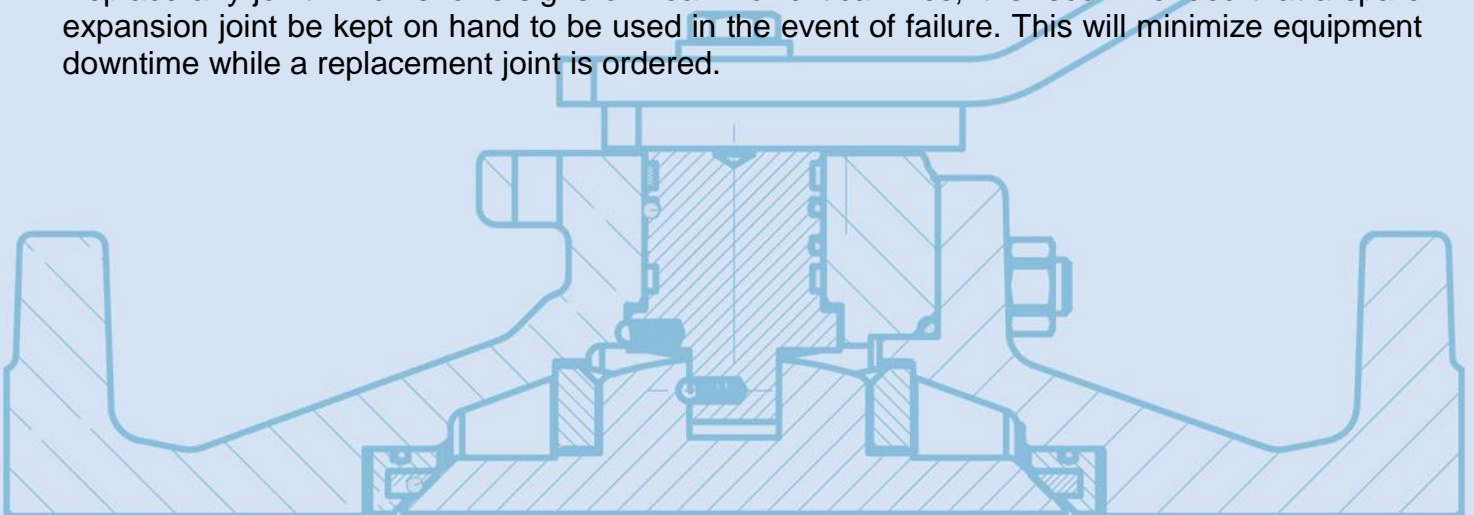

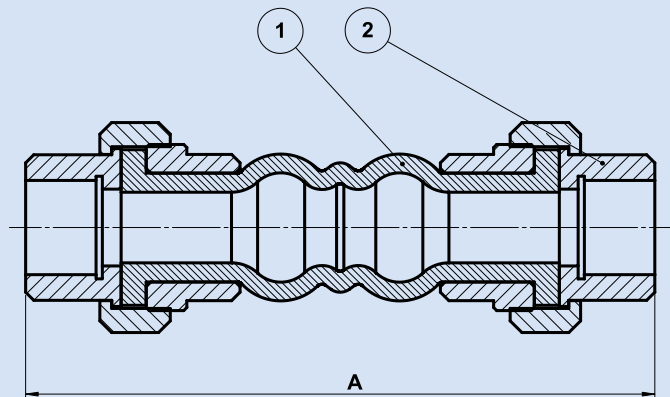

1	Body	EPDM
2	Union	Galvanized Cast Iron – GGG25

